

EUROPEAN SPACE AGENCY
CONTRACT REPORT

The work described in this report was done under ESA contract.
Responsibility for the contents resides in the author or organisation that prepared it.

Survey of Total Ionising Dose Tolerance of Power Bipolar Transistors and Silicon Carbide Devices for JUICE

**TN5.11
TID Test Report for
SiC Schottky Diode
SML020DH12**

**Manufacturer:
Semelab**

Date code/Lot code: HM14070

Report no.	Version	Date	NEO no.
024/2017	1.0	2018-12-10	NEO-14-086
Author	Coauthors	Checked by	Project
Michael Steffens +49 2251 18-222 michael.steffens@int.fraunhofer.de	--	Paschkowski	Survey of Total Ionising Dose Tolerance of Power Bipolar Transistors and Silicon Carbide Devices for JUICE (AO/1-7859/14/NL/SW)
Customer	Project management		
European Space Agency (ESA), contract number 4000113976/15/NL/RA	Project Coordinator: Stefan Höffgen (INT) ESA Technical Project Officer: Marc Poizat (ESA/ESTEC)		



Document approval

Project	AO/1-8148/14/NL/SFe
Project Title	Survey of total ionising dose tolerance of power bipolar transistors and Silicon Carbide devices for JUICE
Doc ID	D5.11
Document Title	TN5.11 TID Test Report for SiC Schottky Diode SML020DH12
Issue.Revision	1
Date	2018-12-10

Prepared by	
	Name: Michael Steffens, INT

Approved by	
	Name: Stefan Höffgen, INT

Accepted by	
	Name: Marc Poizat, ESTEC

Version history

Table 1: Revision history

Version	Date	Changed by	Changes
1.0	2018-12-10	Steffens	Initial release
2.0	-	-	
	-	-	

Table of contents

	Document approval.....	2
1	Introduction	5
2	Summary	6
3	Sample preparations	8
4	Irradiation conditions.....	10
5	Measurement parameters	14
6	Results.....	18
A	Fraunhofer INT.....	27
B	Irradiation details	30
C	Irradiation documentation.....	33

List of figures

Figure 1: Overview of results.....	7
Figure 2: The ESD package with the samples.....	8
Figure 3: Sample marking.....	9
Figure 4: Bias board.....	11
Figure 5: Board fixture at TK1000B.....	11
Figure 6: Bias conditions.....	12
Figure 7: Biasing equipment.....	12
Figure 8: Environment variables during irradiation.....	13
Figure 9: Measurement equipment/setup.....	15
Figure 10: Test setup: SMUs.....	16
Figure 11: Environment variables during measurements.....	17
Figure 12: TK1000B irradiation facility.....	30

List of tables

Table 1: Revision history.....	2
Table 2: Summary.....	6
Table 3: Sample shipment.....	8
Table 4: Sample marking:.....	9
Table 5: Irradiation steps.....	10
Table 6: Environmental variables during irradiation.....	13
Table 7: Measurement parameters.....	14
Table 8: Measurement equipment.....	15
Table 9: Environment variables during measurements.....	17

1 Introduction

1.1 Scope

The Fraunhofer Institute for Technological Trend Analysis (INT) carried out a series of Co-60 irradiations on SiC Schottky Diode SML020DH12 from Semelab for the ESA project "Survey of Total Ionizing Dose Tolerance of Power Bipolar Transistors and Silicon Carbide Devices for JUICE" (ESA-TOPSIDE, AO/1-8148/14/NL/SFe) under contract number 4000113976/15/NL/RA.

This reports documents the preparation, execution and the results of these tests.

1.2 Applicable Documents

- [AD1] ITT/AO/1-8148/14/NL/SFe "Statement of work: Survey of Total Ionizing Dose Tolerance of Power Bipolar Transistors and Silicon Carbide Devices for JUICE"
- [AD2] Proposal for ITT/AO/1-8148/14/NL/SFe, Fraunhofer INT

1.3 Reference Documents

- [1] Website of Fraunhofer INT: <http://www.int.fraunhofer.de>
- [2] Guidelines for Evaluating and Expressing the Uncertainty of NIST Measurement Results, B.N. Taylor and C.E. Kuyatt, NIST Technical Note 1297, 1994, <http://www.nist.gov/pml/pubs/tn1297/index.cfm>.
- [3] ESCC Basic Specification No. 22900, issue 5, June 2016
- [4] Datasheet of SiC Schottky Diode SML020DH12, "SILICON CARBIDE POWER SCHOTTKY RECTIFIER DIODE SML020DH12", Semelab, Document Number 8960 Issue 2
- [5] TN2.11 "TID Test Plan SML020DH12 (Schottky Diode)", Issue 1, Revision 1, 2017-02-13
- [6] MIL-STD-883K w/CHANGE 2, Method 1019.9, "Ionizing Radiation (Total Dose) Test Procedure", 2017

2 Summary

Table 2: Summary

Test Report Number	024/2017
Project (INT)	NEO-14-086
Customer	European Space Agency (ESA), contract number 4000113976/15/NL/RA
Contact	Project Coordinator: Stefan Höffgen (INT) ESA Technical Project Officer: Marc Poizat (ESA/ESTEC)
ESA project / contract number	AO/1-8148/14/NL/SFe 4000113976/15/NL/RA
Device under test	SML020DH12
Family	SiC Schottky Diode
Technology	SiC Power Schottky Rectifier Diode
Package	TO258 (TO-258AA)
Date code / Wafer lot	HM14070
SN	Biased (5x): # 2, 3, 4, 5, 6 Unbiased (5x): # 7, 8, 9, 10, 11 Reference (1x): # 1
Manufacturer	Semelab
Irradiation test house	Fraunhofer INT
Radiation source	Co-60
Irradiation facility	TK1000B
Generic specification	ESCC 22900 Iss. 5
Detail specification	ESCC 22900 Iss. 5
Test plan	TN2.11 "TID Test Plan SML020DH12 (Schottky Diode)", Issue 1, Revision 1, 2017-02-13
Max. test level	1 Mrad(Si)
Dose steps	Multiple: 30, 50, 100, 300, 500, 1000 krad(Si)
Dose rate	8.76 krad(Si)/h
Start of irradiation	2017-03-01 04:03:31
Stop of irradiation	2017-03-06 08:03:35
Non-Homogeneity in DUT	11.1%

Annealing	24h @RT, 168h @ 100°C
Electrical measurements/ Parameters tested	$V_{F1}, V_{F2}, I_{R1}, I_{R2}$

2.1 Overview of results

Figure 1: Overview of results

Pass/Fail		Total Dose [krad (Si)]							Annealing	
		0	30	50	100	300	500	1000	24h @RT	68h @ 100°C
VF1	On									
	Off									
VF2	On									
	Off									
IR1	On									
	Off									
IR2	On									
	Off									

2.2 Comments

- Due to a limited number of samples, some DUTs were used for other tests after conduction of this TID campaign (see Table 4).
- The field non-homogeneity of 11.1% ($\approx \pm 5.5\%$) is calculated across the package dimensions. The non-homogeneity in the sensitive volume should be much lower.
- The TID tests of SiC JFET IJW120R100T1 of the same project were performed simultaneously at the same facility TK1000B.
- During the conduction of the test campaign, two deviations from the requirements of ESCC 22900 occurred: the time gap between the end of one step and the start of the next step where up to 2 minutes longer than allowed.

3 Sample preparations

3.1 Sample shipment

A total of 30 Samples were procured by INT at a commercial supplier (Mouser Electronics) for the conduction of these tests for ESA. The parcel contained devices with one identification code (HM14070). The original package from Semelab indicates this as lot number.

Table 3: Sample shipment

Samples ordered	Samples received	Samples sent back
December 2015	December 2015	still at INT (partially used for other tests in this project)

Figure 2: The ESD package with the samples



3.2 Sample identification/ marking

The samples were soldered to adapter pins, to ease the mounting to the board, exchanging, plugging and storage of the samples.

The samples were colour marked to differentiate the samples between each other and to separate the samples of the different campaigns or types.

Figure 3: Sample marking



3.3 Sample safekeeping

The samples were stored in an Electro-Static Discharge (ESD) box (Figure 3) to handle them safely during the test, the interim storage after the last measurement and the final shipment.

Table 4: Sample marking: Due to a limited number of samples, some DUTs were used for other tests after conduction of this TID campaign

Condition	Label	S/N*	Color Code	Comment
Control sample	REF#1	1	Black	
Biased	ON#1	2	Brown	further used for proton SEE tests
	ON#2	3	Red	further used for proton SEE tests
	ON#3	4	Orange	further used for proton SEE tests
	ON#4	5	Yellow	
	ON#5	6	Green	
Unbiased	OFF#1	7	Blue	
	OFF#2	8	Purple	
	OFF#3	9	Grey	
	OFF#4	10	White	
	OFF#5	11	Brown/Black	

* S/N indicated on package

4 Irradiation conditions

4.1 Irradiation steps

Table 5: Irradiation steps

	Step [krad(Si)]	Total [krad (Si)]	Doserate [krad(Si)/h]	Start Irr.	Stop Irr.	Duration [d h:m:s]	Start Tests	Stop Tests	Dur. [h:m]
0	0.00	0		-	-	--	28.02.2017 19:03	28.02.2017 19:30	0:27
1	30.00	30	8.76	01.03.2017 04:03:31	01.03.2017 07:28:57	0d 03:25:26	01.03.2017 07:58	01.03.2017 08:19	0:21
2	20.00	50	8.76	01.03.2017 09:24:49	01.03.2017 11:41:45	0d 02:16:56	01.03.2017 12:29	01.03.2017 12:51	0:22
3	50.00	100	8.76	01.03.2017 13:42:00	01.03.2017 19:24:24	0d 05:42:24	01.03.2017 19:28	01.03.2017 19:48	0:20
4	200.00	300	8.76	01.03.2017 21:21:08	02.03.2017 20:10:28	0d 22:49:20	02.03.2017 20:53	02.03.2017 21:17	0:24
5	200.00	500	8.76	02.03.2017 22:12:16	03.03.2017 21:01:35	0d 22:49:19	03.03.2017 21:33	03.03.2017 21:48	0:15
6	500.00	1000	8.76	03.03.2017 23:00:09	06.03.2017 08:03:35	2d 09:03:26	06.03.2017 08:13	06.03.2017 08:38	0:25
7	24 h @ RT			06.03.2017 09:10:00	07.03.2017 09:10:00	1d 00:00:00	07.03.2017 09:47	07.03.2017 10:00	
8	168 h @100°C			07.03.2017 10:10:00	14.03.2017 13:00:00	7d 02:50:00	14.03.2017 13:15	14.03.2017 13:30	

The TID tests of SiC JFET IJW120R100T1 of the same project were performed simultaneously at the same facility TK1000B.

During the conduction of the test campaign, two deviations from the requirements of ESCC 22900 occurred: the time gap between the end of one step and the start of the next step where up to 2 minutes longer than allowed.

4.2 Sample holder

A custom-build printed-circuit board (Figure 4) was manufactured to

- bias the samples according to the circuit-layout of the irradiation test plan [5] (see also chapter 4.3)
- fix the samples under the radiation source (see also chapter 4.3 Geometry)
- irradiate the samples homogeneously.

4.3 Geometry

The irradiation parameters correspond to a sample-distance of 16.1 cm from the TK1000B source (Figure 5) to the object minimum.

In each test a PMMA layer of 5 mm was placed over the DUTs to achieve charge equilibrium.

Figure 4: Bias board

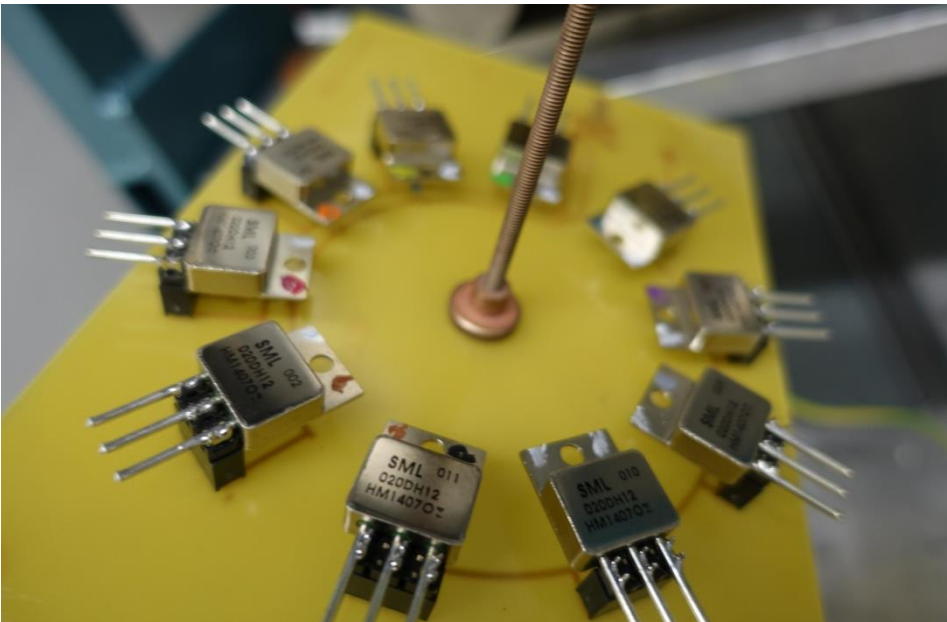
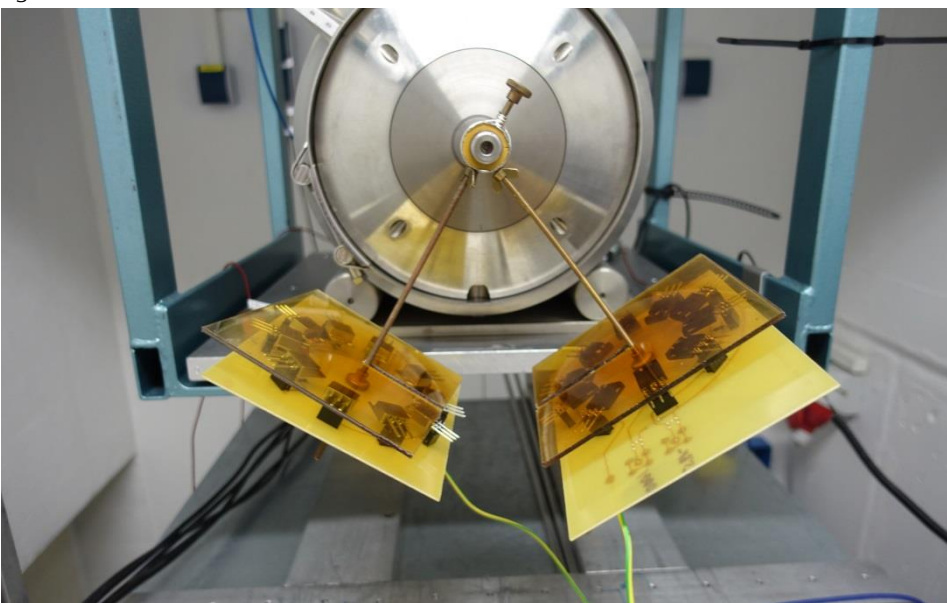

Figure 5: Board fixture at TK1000B



4.4 Bias conditions

During the irradiation and the subsequent annealing the samples were biased or operated according to the circuit-description of the irradiation test plan [5] (see Figure 6).

A fug HCE 35-1250 voltage supply (Eq.Id E-PS1-044, supply on right side of Figure 7) was used for biasing. The supply was not calibrated but the voltage was checked with a calibrated voltmeter.

During transport from the irradiation site to the electrical measurement site and back again all terminals were shorted.

Figure 6: Bias conditions

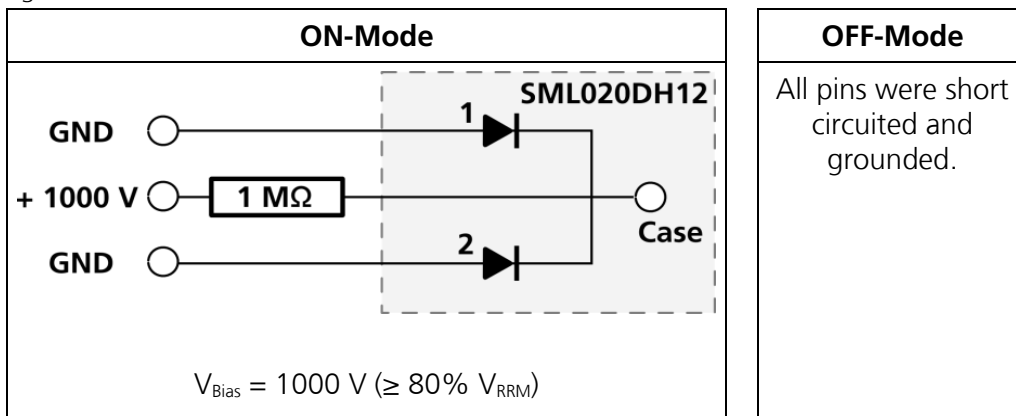
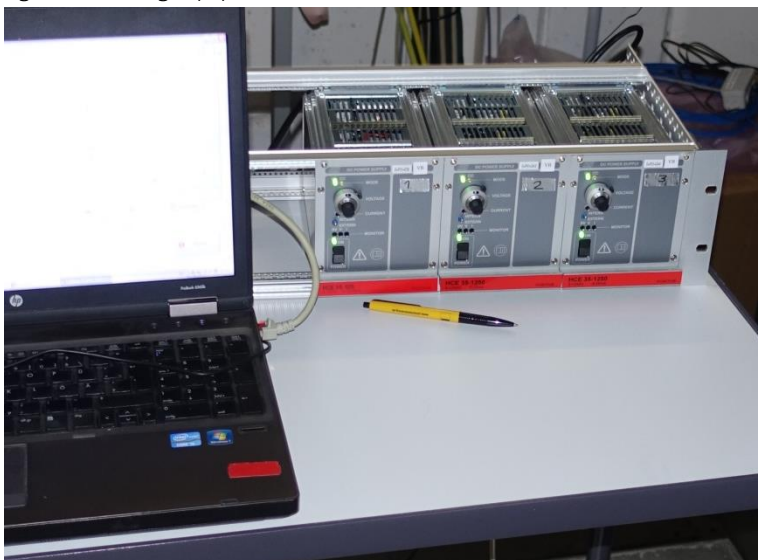

Figure 7: Biasing equipment



4.5 Environmental variables

All irradiation steps were done in air. The samples at TK1000B were irradiated in ambient light. The parameters of the humidity and the temperature are given in the following tables and figures.

Table 6: Environmental variables during irradiation

Parameter	Value and Unit	Remarks
Humidity	32.3% ± 2.1%	Non-condensing, during irradiation and first annealing (24 h)
Temperature	22.0 °C ± 0.3 °C	During irradiation and first annealing (24 h)
Temperature	100.0 ± 3.0 °C	During second annealing at 100°C.

Figure 8: Environment variables during irradiation.

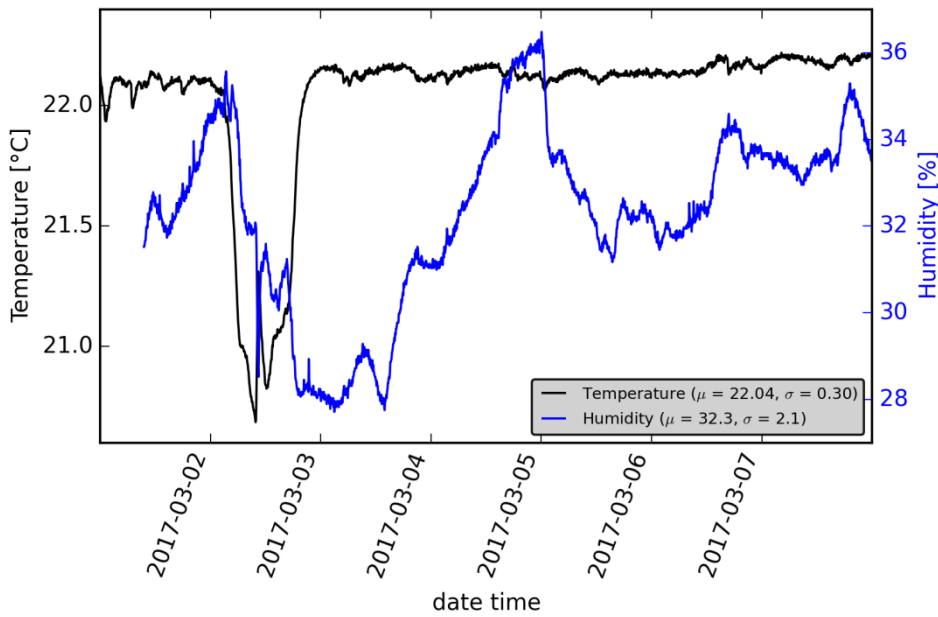

5 Measurement parameters

The measurement of the electrical parameters was done by Fraunhofer INT in accordance with the measurements standards and test methods of ESA, MIL and IEC.

The test plan based on the ESA Basic Specification No. 22900 [3] in general and the irradiation test plan [5] in particular.

Parameters listed in the following Table 7 were measured before and after each irradiation step and each annealing step.

5.1 Measurement parameters

Table 7: Measurement parameters. based on [4], taken from [5]

No.	Characteristics	Symbol	MIL-STD-750 Test Method	Test Conditions
1	Forward Voltage	V_{F1}	4011	Diode 1, $I_F = 10$ A (per device), Note 1
2		V_{F2}		Diode 2, $I_F = 10$ A (per device), Note 1
3	Reverse Current	I_{R1}	4016	Diode 1, $V_R = V_{RRM} = 1200$ V
4		I_{R2}		Diode 2, $V_R = V_{RRM} = 1200$ V

Note 1: As discussed with the technical officer, pulse widths were increased to 1 ms while maintaining $< 2\%$ duty cycle

5.2 Measurement equipment

Table 8: Measurement equipment

Equipment	Manufacturer	Model	INT-Code	Calibr. due	Measurement
System Source Meter	Keithley	2651A	E-SMU-011	11/2017	V_{F1} , V_{F2}
High Power System Source-Meter	Keithley	2657A	E-SMU-008	11/2017	I_{R1} , I_{R2}
Test Fixture	Keithley	8010	E-SPAT-004	--	all

Figure 9: Measurement equipment/setup



Figure 10: Test setup: SMUs

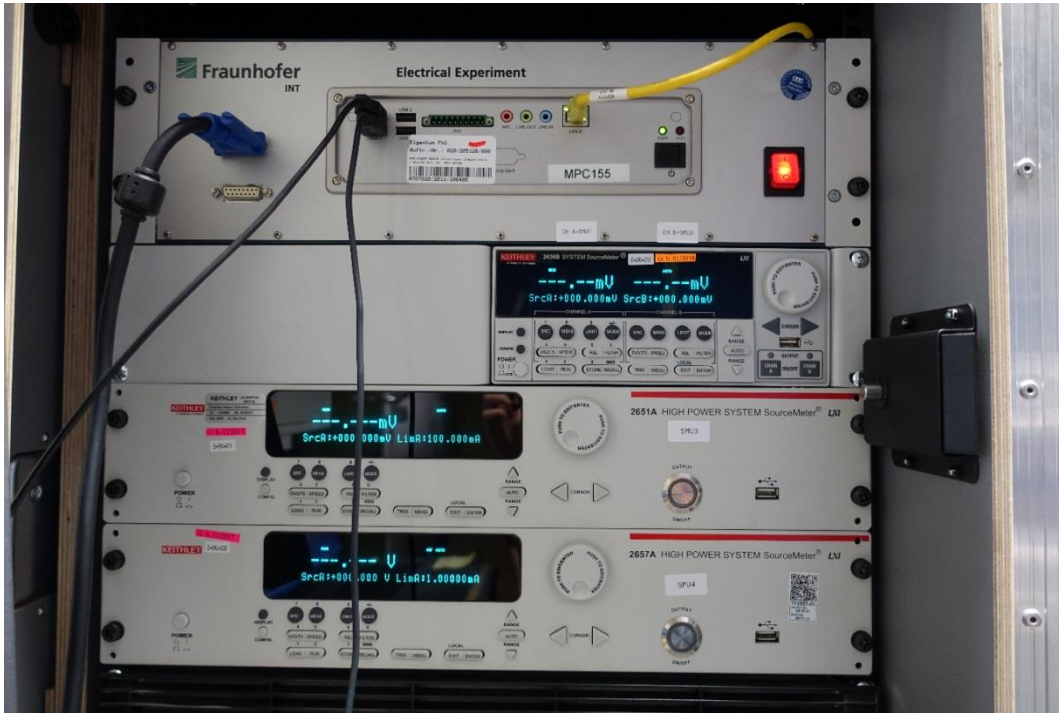

5.3 Measurement procedures

Procedures according to the MIL test methods given in Table 7 and Notes 1+2.

Measurements were programmed using the software Keithley ASC Basic allowing timed operation of the SMUs during pulses (e.g. using a fixed delay between pulse rise and parameter readout times).

5.4 Environmental variables

All measurement and annealing steps were done in air. The samples are measured in a lightproof measuring-case. The parameters of the humidity and the temperature during the tests in the ESD area are given in the following table and figure.

Table 9: Environment variables during measurements

Test cond.	Total Dose [krad (Si)]							Annealing	
	0	30	50	100	300	500	1000	24h @RT	68h @ 100°C
Temperature [°C]	22.6E+0	21.9E+0	22.4E+0	21.7E+0	22.2E+0	22.2E+0	22.1E+0	22.1E+0	21.4E+0
Humidity [%]	51.4E+0	43.0E+0	45.3E+0	42.0E+0	40.4E+0	41.4E+0	38.2E+0	40.5E+0	41.4E+0

Figure 11: Environment variables during measurements

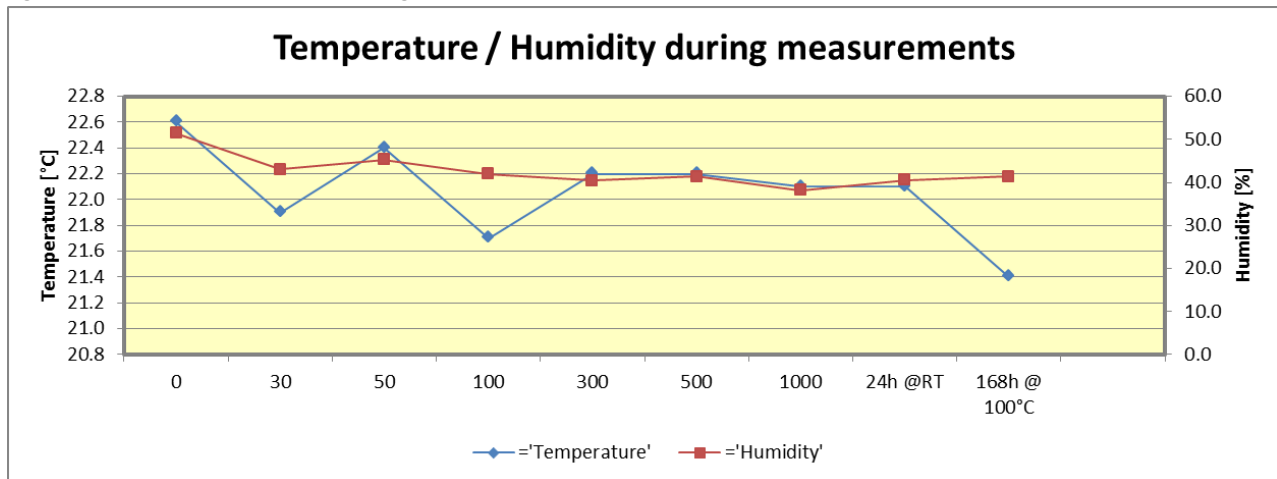

6 Results

6.1 Overview: Pass/Fail

Pass/Fail		Total Dose [krad (Si)]							Annealing	
		0	30	50	100	300	500	1000	24h @RT	68h @ 100°C
VF1	On									
	Off									
VF2	On									
	Off									
IR1	On									
	Off									
IR2	On									
	Off									

6.2 Forward Voltage (1)

Forward Voltage (1)

VF1 in V

Limit: $x < 1.8$

SML020DH12

Date-/Lotcode: HM14070

ON-Mode	Total Dose [krad (Si)]							Annealing	
	0	30	50	100	300	500	1000	24h @RT	68h @ 100°C
On#1	1.5E+0	1.5E+0	1.5E+0	1.5E+0	1.5E+0	1.5E+0	1.5E+0	1.5E+0	1.5E+0
On#2	1.5E+0	1.5E+0	1.5E+0	1.5E+0	1.5E+0	1.5E+0	1.5E+0	1.5E+0	1.5E+0
On#3	1.5E+0	1.5E+0	1.5E+0	1.5E+0	1.5E+0	1.5E+0	1.5E+0	1.5E+0	1.5E+0
On#4	1.5E+0	1.5E+0	1.5E+0	1.5E+0	1.5E+0	1.5E+0	1.5E+0	1.5E+0	1.5E+0
On#5	1.5E+0	1.5E+0	1.5E+0	1.5E+0	1.5E+0	1.5E+0	1.5E+0	1.5E+0	1.5E+0
Radiation-Mean ON	1.5E+0	1.5E+0	1.5E+0	1.5E+0	1.5E+0	1.5E+0	1.5E+0	1.5E+0	1.5E+0
Standarddeviation	13.3E-3	13.8E-3	13.7E-3	10.8E-3	14.3E-3	14.3E-3	14.3E-3	13.9E-3	13.2E-3
Mean + $k\sigma$	1.5E+0	1.5E+0	1.5E+0	1.5E+0	1.6E+0	1.6E+0	1.6E+0	1.6E+0	1.6E+0
Mean - $k\sigma$	1.5E+0	1.5E+0	1.5E+0	1.5E+0	1.5E+0	1.5E+0	1.5E+0	1.5E+0	1.5E+0
OFF-Mode	Total Dose [krad (Si)]							Annealing	
	0	30	50	100	300	500	1000	24h @RT	68h @ 100°C
Off#1	1.5E+0	1.5E+0	1.5E+0	1.5E+0	1.5E+0	1.5E+0	1.5E+0	1.5E+0	1.5E+0
Off#2	1.5E+0	1.5E+0	1.5E+0	1.5E+0	1.5E+0	1.5E+0	1.5E+0	1.5E+0	1.5E+0
Off#3	1.5E+0	1.5E+0	1.5E+0	1.5E+0	1.5E+0	1.5E+0	1.5E+0	1.5E+0	1.5E+0
Off#4	1.5E+0	1.5E+0	1.5E+0	1.5E+0	1.5E+0	1.5E+0	1.5E+0	1.5E+0	1.5E+0
Off#5	1.5E+0	1.5E+0	1.5E+0	1.5E+0	1.5E+0	1.5E+0	1.5E+0	1.5E+0	1.5E+0
Radiation-Mean OFF	1.5E+0	1.5E+0	1.5E+0	1.5E+0	1.5E+0	1.5E+0	1.5E+0	1.5E+0	1.5E+0
Standarddeviation	14.8E-3	14.3E-3	13.4E-3	13.2E-3	13.8E-3	14.6E-3	15.8E-3	13.7E-3	13.5E-3
Mean + $k\sigma$	1.6E+0	1.6E+0	1.6E+0	1.6E+0	1.6E+0	1.6E+0	1.6E+0	1.6E+0	1.6E+0
Mean - $k\sigma$	1.5E+0	1.5E+0	1.5E+0	1.5E+0	1.5E+0	1.5E+0	1.5E+0	1.5E+0	1.5E+0
Reference	Total Dose [krad (Si)]							Annealing	
	0	30	50	100	300	500	1000	24h @RT	68h @ 100°C
Ref1	1.5E+0	1.5E+0	1.5E+0	1.5E+0	1.5E+0	1.5E+0	1.5E+0	1.5E+0	1.5E+0
Typ. Value	1.6E+0	1.6E+0	1.6E+0	1.6E+0	1.6E+0	1.6E+0	1.6E+0	1.6E+0	1.6E+0
Max. Value	1.8E+0	1.8E+0	1.8E+0	1.8E+0	1.8E+0	1.8E+0	1.8E+0	1.8E+0	1.8E+0

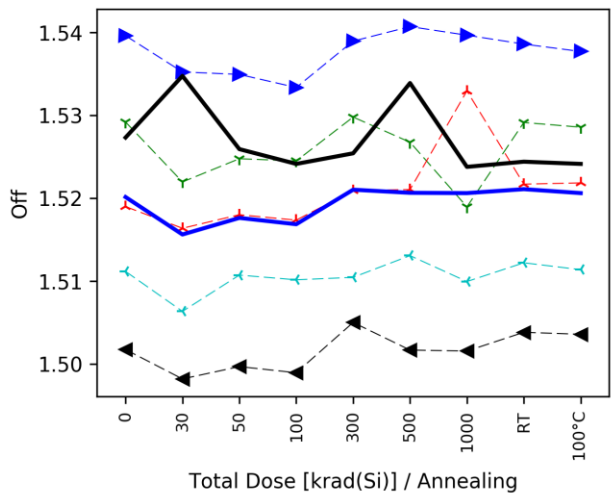
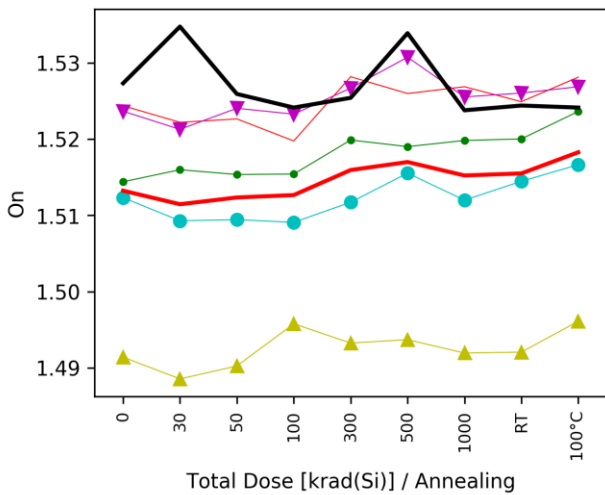
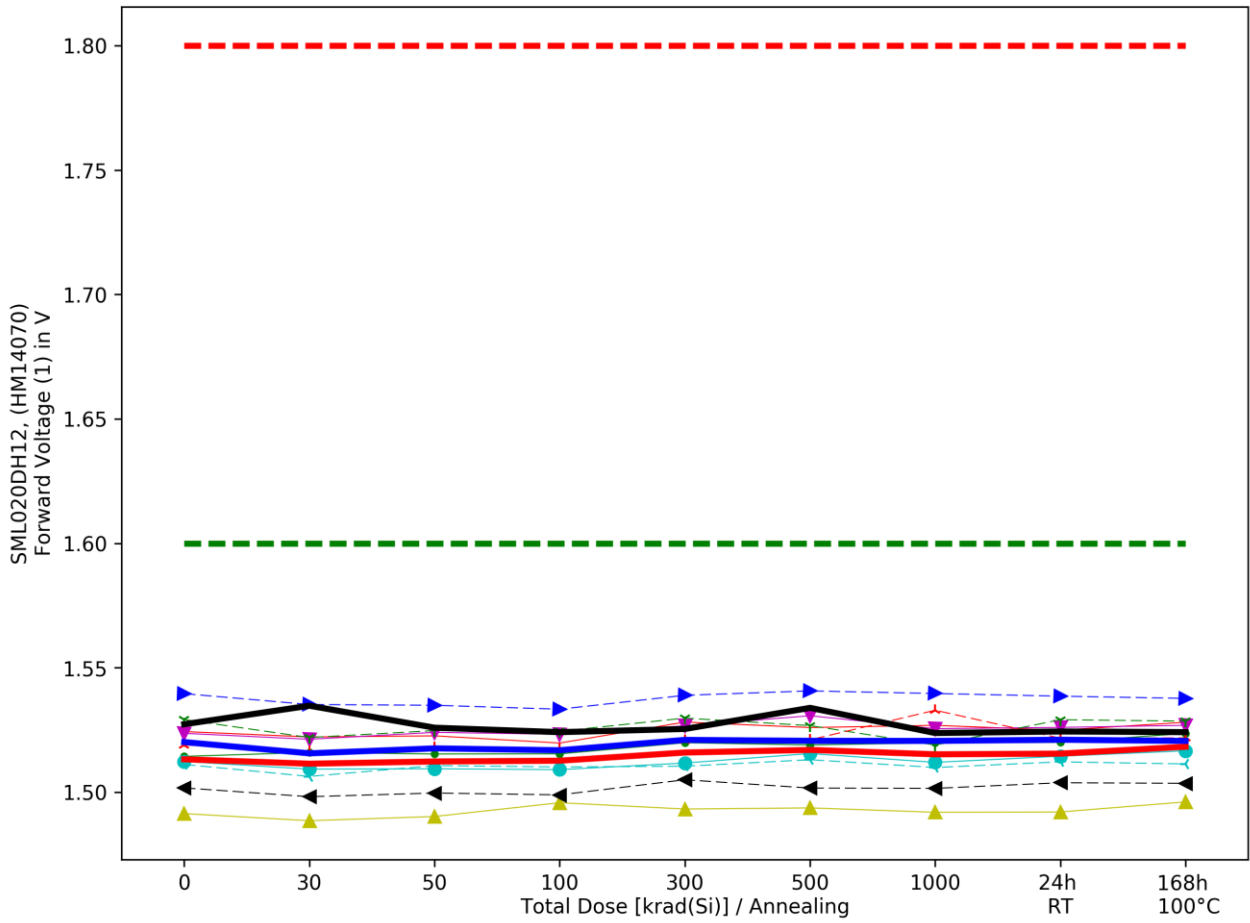

6.3 Forward Voltage (2)

Forward Voltage (2)

VF2 in V

Limit: $x < 1.8$

SML020DH12

Date-/Lotcode: HM14070

ON-Mode	Total Dose [krad (Si)]							Annealing	
	0	30	50	100	300	500	1000	24h @RT	68h @ 100°C
On#1	1.5E+0	1.5E+0	1.5E+0	1.5E+0	1.5E+0	1.5E+0	1.5E+0	1.5E+0	1.5E+0
On#2	1.5E+0	1.5E+0	1.5E+0	1.5E+0	1.5E+0	1.5E+0	1.5E+0	1.5E+0	1.5E+0
On#3	1.5E+0	1.5E+0	1.5E+0	1.5E+0	1.5E+0	1.5E+0	1.5E+0	1.5E+0	1.5E+0
On#4	1.5E+0	1.5E+0	1.5E+0	1.5E+0	1.5E+0	1.5E+0	1.5E+0	1.5E+0	1.5E+0
On#5	1.5E+0	1.5E+0	1.5E+0	1.5E+0	1.5E+0	1.5E+0	1.5E+0	1.5E+0	1.5E+0
Radiation-Mean ON	1.5E+0	1.5E+0	1.5E+0	1.5E+0	1.5E+0	1.5E+0	1.5E+0	1.5E+0	1.5E+0
Standarddeviation	18.4E-3	18.2E-3	19.7E-3	18.0E-3	19.6E-3	20.8E-3	17.2E-3	20.4E-3	20.1E-3
Mean + $k\sigma$	1.6E+0	1.6E+0	1.6E+0	1.6E+0	1.6E+0	1.6E+0	1.6E+0	1.6E+0	1.6E+0
Mean - $k\sigma$	1.5E+0	1.5E+0	1.5E+0	1.5E+0	1.5E+0	1.5E+0	1.5E+0	1.5E+0	1.5E+0
OFF-Mode	Total Dose [krad (Si)]							Annealing	
	0	30	50	100	300	500	1000	24h @RT	68h @ 100°C
Off#1	1.5E+0	1.5E+0	1.5E+0	1.5E+0	1.5E+0	1.5E+0	1.5E+0	1.5E+0	1.5E+0
Off#2	1.5E+0	1.5E+0	1.5E+0	1.5E+0	1.5E+0	1.5E+0	1.5E+0	1.5E+0	1.5E+0
Off#3	1.5E+0	1.5E+0	1.5E+0	1.5E+0	1.5E+0	1.5E+0	1.5E+0	1.5E+0	1.5E+0
Off#4	1.5E+0	1.5E+0	1.5E+0	1.5E+0	1.5E+0	1.5E+0	1.6E+0	1.5E+0	1.5E+0
Off#5	1.5E+0	1.5E+0	1.5E+0	1.5E+0	1.5E+0	1.5E+0	1.5E+0	1.5E+0	1.5E+0
Radiation-Mean OFF	1.5E+0	1.5E+0	1.5E+0	1.5E+0	1.5E+0	1.5E+0	1.5E+0	1.5E+0	1.5E+0
Standarddeviation	3.7E-3	2.8E-3	2.7E-3	2.6E-3	4.0E-3	2.9E-3	6.6E-3	3.1E-3	2.5E-3
Mean + $k\sigma$	1.5E+0	1.5E+0	1.5E+0	1.5E+0	1.6E+0	1.5E+0	1.6E+0	1.5E+0	1.5E+0
Mean - $k\sigma$	1.5E+0	1.5E+0	1.5E+0	1.5E+0	1.5E+0	1.5E+0	1.5E+0	1.5E+0	1.5E+0
Reference	Total Dose [krad (Si)]							Annealing	
	0	30	50	100	300	500	1000	24h @RT	68h @ 100°C
Ref1	1.5E+0	1.5E+0	1.5E+0	1.5E+0	1.5E+0	1.5E+0	1.5E+0	1.5E+0	1.5E+0
Typ. Value	1.6E+0	1.6E+0	1.6E+0	1.6E+0	1.6E+0	1.6E+0	1.6E+0	1.6E+0	1.6E+0
Max. Value	1.8E+0	1.8E+0	1.8E+0	1.8E+0	1.8E+0	1.8E+0	1.8E+0	1.8E+0	1.8E+0

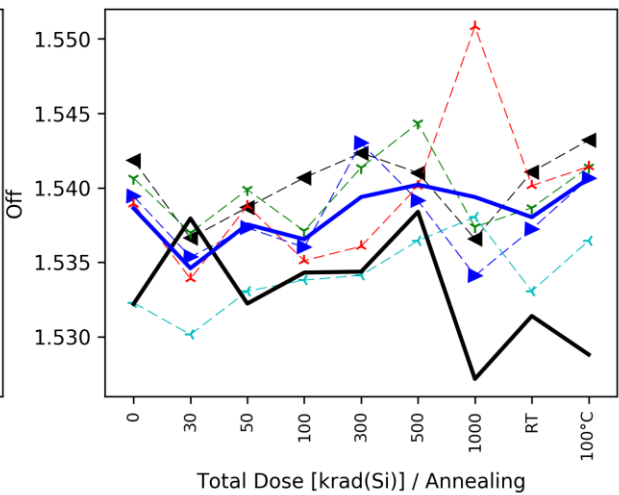
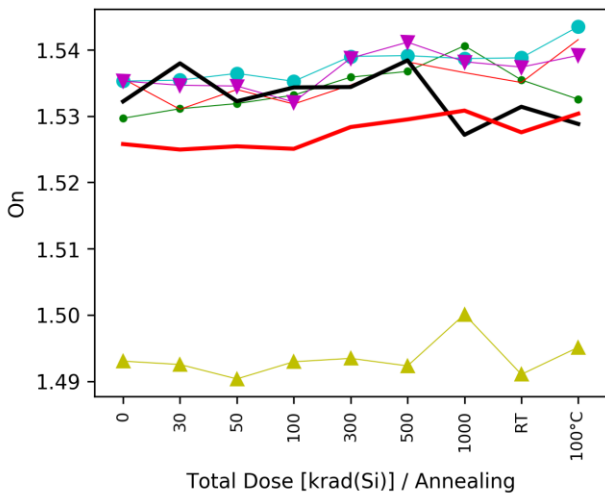
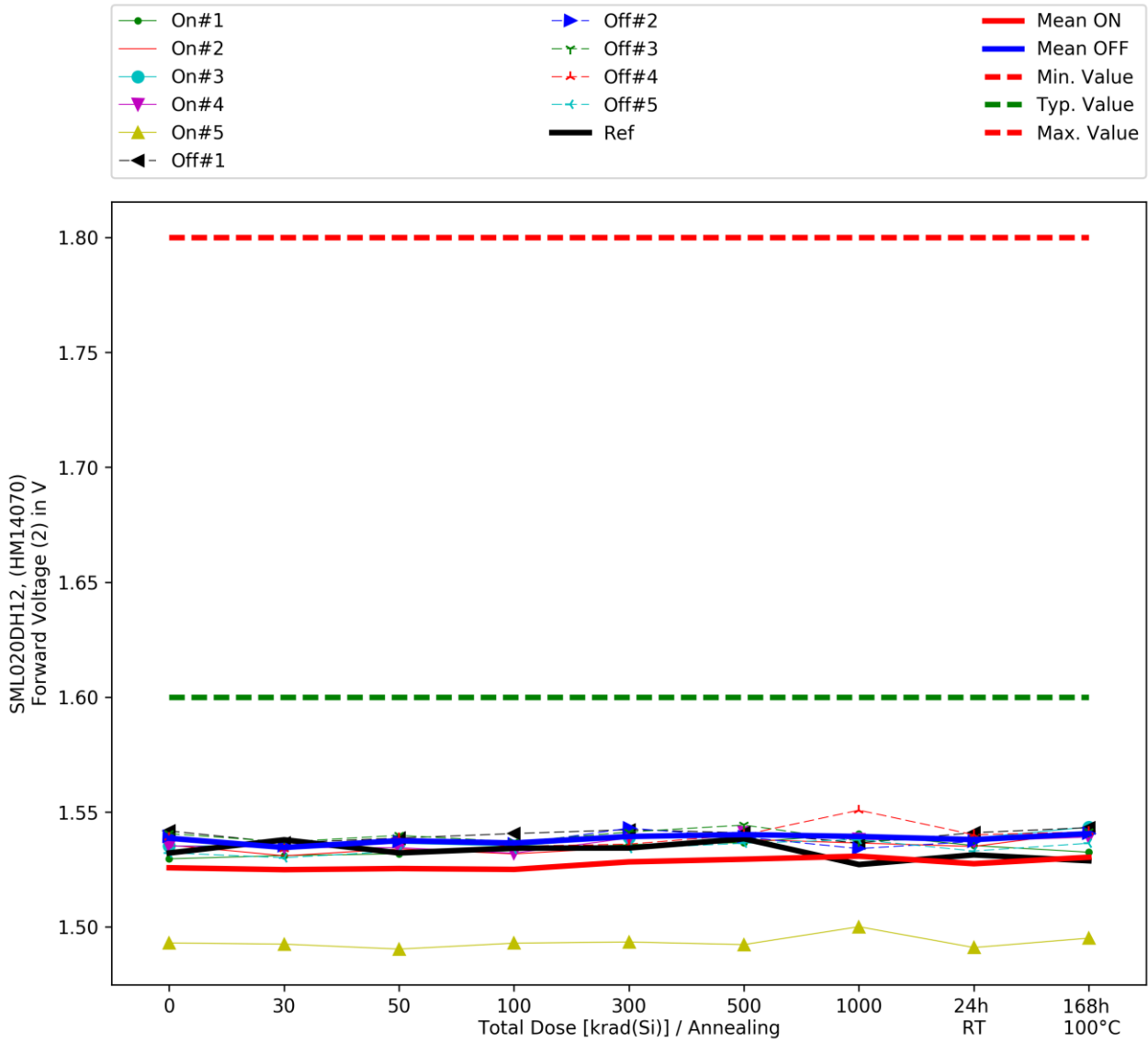

6.4 Reverse Current (1)

Reverse Current (1)

IR1 in A

Limit: -0.0002 < x

SML020DH12

Date-/Lotcode: HM14070

ON-Mode	Total Dose [krad (Si)]							Annealing	
	0	30	50	100	300	500	1000	24h @RT	68h @ 100°C
On#1	-211.4E-9	-186.7E-9	-205.5E-9	-202.8E-9	-214.3E-9	-201.3E-9	-200.4E-9	-199.2E-9	-200.1E-9
On#2	-70.2E-9	-49.9E-9	-66.4E-9	-63.8E-9	-67.9E-9	-67.0E-9	-68.7E-9	-67.7E-9	-66.7E-9
On#3	-145.0E-9	-144.2E-9	-143.4E-9	-138.0E-9	-141.4E-9	-139.6E-9	-137.8E-9	-135.4E-9	-136.7E-9
On#4	-60.1E-9	-41.3E-9	-59.5E-9	-55.4E-9	-61.2E-9	-58.8E-9	-57.0E-9	-58.1E-9	-60.4E-9
On#5	-5.7E-6	-6.4E-6	-6.3E-6	-6.5E-6	-6.7E-6	-7.0E-6	-7.0E-6	-6.9E-6	-7.5E-6
Radiation-Mean ON	-1.2E-6	-1.4E-6	-1.4E-6	-1.4E-6	-1.4E-6	-1.5E-6	-1.5E-6	-1.5E-6	-1.6E-6
Standarddeviation	2.5E-6	2.8E-6	2.8E-6	2.8E-6	3.0E-6	3.1E-6	3.1E-6	3.1E-6	3.3E-6
Mean + kσ	5.6E-6	6.3E-6	6.3E-6	6.4E-6	6.7E-6	7.0E-6	7.0E-6	6.9E-6	7.5E-6
Mean - kσ	-8.1E-6	-9.0E-6	-9.0E-6	-9.2E-6	-9.6E-6	-10.0E-6	-10.0E-6	-9.9E-6	-10.7E-6
OFF-Mode	Total Dose [krad (Si)]							Annealing	
	0	30	50	100	300	500	1000	24h @RT	68h @ 100°C
Off#1	-104.0E-9	-94.2E-9	-102.2E-9	-97.8E-9	-101.7E-9	-100.9E-9	-100.6E-9	-100.6E-9	-100.5E-9
Off#2	-53.2E-9	-49.5E-9	-49.5E-9	-48.1E-9	-50.1E-9	-47.6E-9	-58.6E-9	-47.0E-9	-51.7E-9
Off#3	-33.9E-9	-55.7E-9	-57.5E-9	-55.0E-9	-58.7E-9	-56.0E-9	-59.1E-9	-64.4E-9	-56.9E-9
Off#4	-2.4E-6	-2.4E-6	-2.4E-6	-2.5E-6	-2.5E-6	-2.4E-6	-2.5E-6	-2.5E-6	-2.5E-6
Off#5	-46.6E-9	-60.7E-9	-70.0E-9	-66.4E-9	-70.4E-9	-56.8E-9	-71.8E-9	-72.2E-9	-69.2E-9
Radiation-Mean OFF	-534.5E-9	-538.7E-9	-544.6E-9	-549.2E-9	-551.0E-9	-540.1E-9	-550.8E-9	-559.1E-9	-549.1E-9
Standarddeviation	1.1E-6	1.1E-6	1.1E-6	1.1E-6	1.1E-6	1.1E-6	1.1E-6	1.1E-6	1.1E-6
Mean + kσ	2.4E-6	2.4E-6	2.4E-6	2.4E-6	2.4E-6	2.4E-6	2.4E-6	2.4E-6	2.4E-6
Mean - kσ	-3.4E-6	-3.4E-6	-3.5E-6	-3.5E-6	-3.5E-6	-3.5E-6	-3.5E-6	-3.6E-6	-3.5E-6
Reference	Total Dose [krad (Si)]							Annealing	
	0	30	50	100	300	500	1000	24h @RT	68h @ 100°C
Ref1	-2.2E-6	-2.2E-6	-2.2E-6	-2.3E-6	-2.2E-6	-2.2E-6	-2.2E-6	-2.2E-6	-2.2E-6
Min. Value	-200.0E-6	-200.0E-6	-200.0E-6	-200.0E-6	-200.0E-6	-200.0E-6	-200.0E-6	-200.0E-6	-200.0E-6
Typ. Value	-10.0E-6	-10.0E-6	-10.0E-6	-10.0E-6	-10.0E-6	-10.0E-6	-10.0E-6	-10.0E-6	-10.0E-6

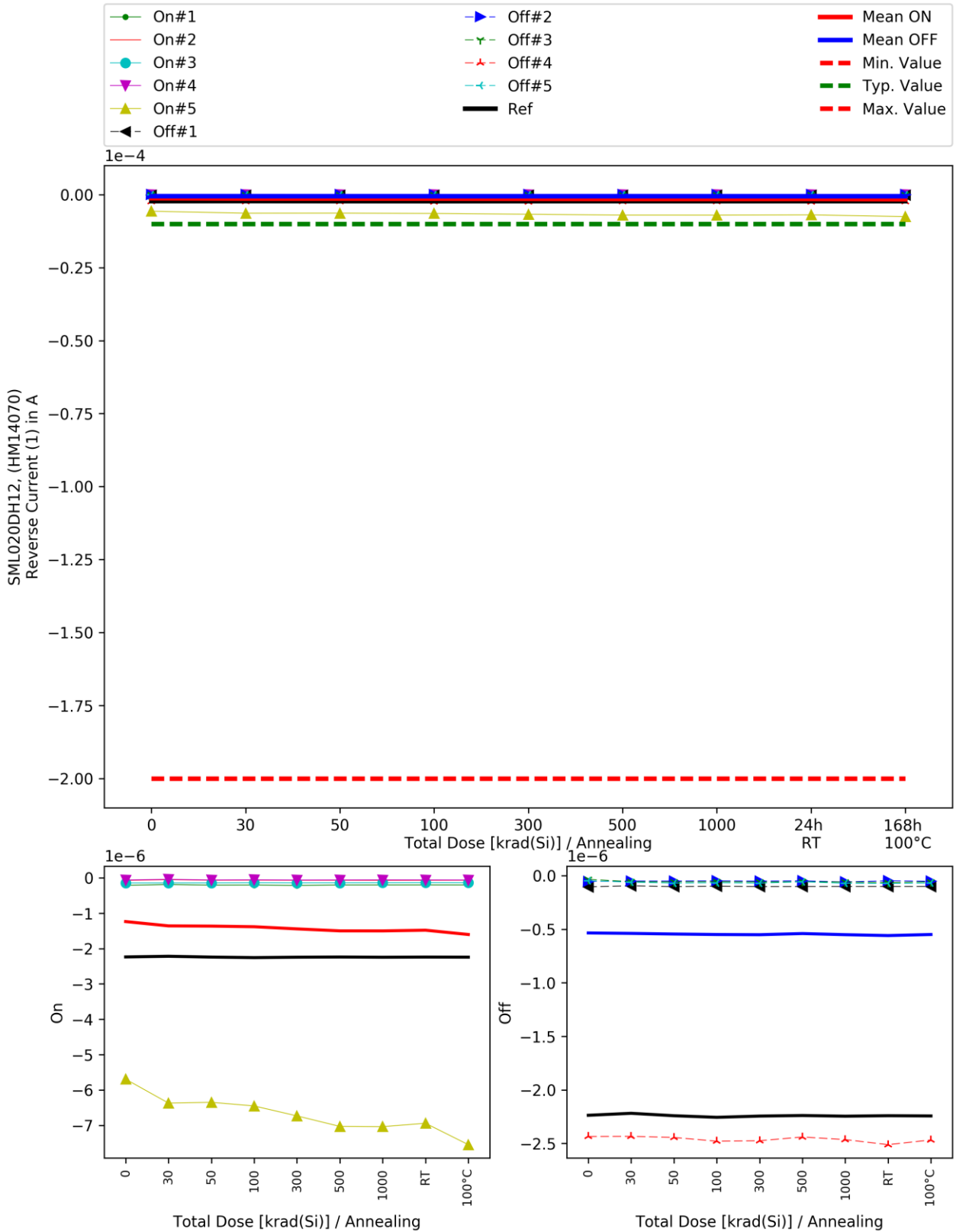

6.5 Reverse Current (2)

Reverse Current (2)

IR2 in A

Limit: -0.0002 < x

SML020DH12

Date-/Lotcode: HM14070

ON-Mode	Total Dose [krad (Si)]							Annealing	
	0	30	50	100	300	500	1000	24h @RT	68h @ 100°C
On#1	-688.8E-9	-703.1E-9	-732.0E-9	-716.9E-9	-706.0E-9	-698.6E-9	-726.5E-9	-730.6E-9	-728.8E-9
On#2	-98.1E-9	-57.9E-9	-72.5E-9	-67.8E-9	-69.0E-9	-70.1E-9	-69.2E-9	-69.9E-9	-61.7E-9
On#3	-699.3E-9	-694.3E-9	-717.2E-9	-715.4E-9	-736.6E-9	-738.9E-9	-743.8E-9	-743.9E-9	-731.2E-9
On#4	-167.5E-9	-150.6E-9	-170.3E-9	-164.9E-9	-168.1E-9	-170.6E-9	-168.3E-9	-168.3E-9	-166.0E-9
On#5	-1.8E-6	-1.8E-6	-1.9E-6	-1.9E-6	-1.9E-6	-1.9E-6	-1.9E-6	-1.9E-6	-2.7E-6
Radiation-Mean ON	-681.3E-9	-683.4E-9	-713.0E-9	-711.6E-9	-724.1E-9	-720.7E-9	-727.7E-9	-731.3E-9	-886.7E-9
Standarddeviation	661.9E-9	697.7E-9	715.9E-9	726.2E-9	744.8E-9	737.9E-9	740.6E-9	745.7E-9	1.1E-6
Mean + kσ	1.1E-6	1.2E-6	1.2E-6	1.3E-6	1.3E-6	1.3E-6	1.3E-6	1.3E-6	2.1E-6
Mean - kσ	-2.5E-6	-2.6E-6	-2.7E-6	-2.7E-6	-2.8E-6	-2.7E-6	-2.8E-6	-2.8E-6	-3.9E-6
OFF-Mode	Total Dose [krad (Si)]							Annealing	
	0	30	50	100	300	500	1000	24h @RT	68h @ 100°C
Off#1	-58.2E-9	-48.6E-9	-56.0E-9	-52.7E-9	-58.0E-9	-55.6E-9	-55.1E-9	-55.1E-9	-58.5E-9
Off#2	-3.8E-6	-3.8E-6	-3.8E-6	-3.9E-6	-3.9E-6	-3.9E-6	-3.9E-6	-3.9E-6	-3.9E-6
Off#3	-31.2E-9	-48.0E-9	-53.7E-9	-52.0E-9	-55.5E-9	-52.6E-9	-54.3E-9	-81.6E-9	-53.4E-9
Off#4	-32.7E-9	-43.7E-9	-55.2E-9	-53.5E-9	-56.0E-9	-53.6E-9	-56.8E-9	-58.7E-9	-58.1E-9
Off#5	-35.9E-9	-50.0E-9	-57.9E-9	-57.3E-9	-61.5E-9	-58.3E-9	-61.0E-9	60.8E-9	-60.9E-9
Radiation-Mean OFF	-796.4E-9	-806.8E-9	-809.6E-9	-815.0E-9	-818.4E-9	-815.7E-9	-818.1E-9	-798.5E-9	-820.8E-9
Standarddeviation	1.7E-6	1.7E-6	1.7E-6	1.7E-6	1.7E-6	1.7E-6	1.7E-6	1.7E-6	1.7E-6
Mean + kσ	3.8E-6	3.8E-6	3.8E-6	3.9E-6	3.8E-6	3.8E-6	3.8E-6	3.9E-6	3.9E-6
Mean - kσ	-5.4E-6	-5.5E-6	-5.4E-6	-5.5E-6	-5.5E-6	-5.5E-6	-5.5E-6	-5.5E-6	-5.5E-6
Reference	Total Dose [krad (Si)]							Annealing	
	0	30	50	100	300	500	1000	24h @RT	68h @ 100°C
Ref1	-265.7E-9	-243.5E-9	-262.2E-9	-255.8E-9	-261.8E-9	-258.1E-9	-260.1E-9	-265.1E-9	-261.6E-9
Min. Value	-200.0E-6	-200.0E-6	-200.0E-6	-200.0E-6	-200.0E-6	-200.0E-6	-200.0E-6	-200.0E-6	-200.0E-6
Typ. Value	-10.0E-6	-10.0E-6	-10.0E-6	-10.0E-6	-10.0E-6	-10.0E-6	-10.0E-6	-10.0E-6	-10.0E-6

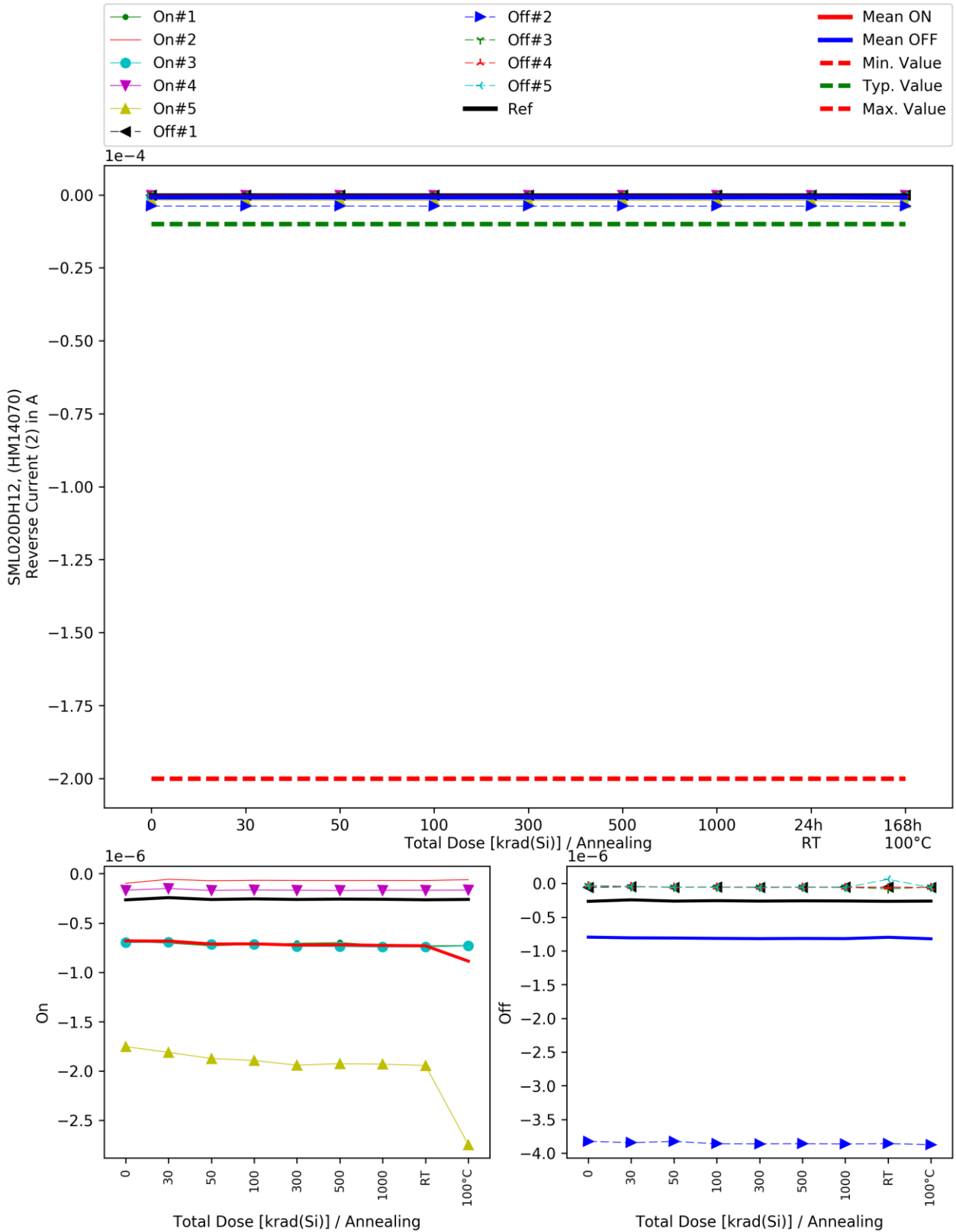

A Fraunhofer INT

A.1. About the institute

The Fraunhofer Institute for Technological Trend Analysis INT provides scientifically sound assessments and counselling on the entire spectrum of technological developments. On this basis, the Institute conducts Technology Forecasting, making possible a long-term approach to strategic research planning. Fraunhofer INT constantly applies this competence in projects tailor-made for our clients.

Over and above these skills, we run our own experimental and theoretical research on the effects of ionizing and electromagnetic radiation on electronic components, as well as on radiation detection systems. To this end, INT is equipped with the latest measurement technology. Our main laboratory and large-scale appliances are radiation sources, electromagnetic simulation facilities and detector systems that cannot be found in this combination in any other civilian body in Germany.

For more than 40 years, INT has been a reliable partner for the Federal German Ministry of Defence, which it advises in close cooperation and for which it carries out research in technology analysis and strategic planning as well as radiation effects. INT also successfully advises and conducts research for domestic and international civilian clients: both public bodies and industry, from SMEs to DAX 30 companies.

Further information can be found on the website [1].

A.2. Business unit Nuclear Effects in Electronics and Optics

The Business Unit „Nuclear Effects in Electronic and Optics (NEO)“ at Fraunhofer INT investigates the effects of ionizing radiation on electronic, optoelectronic, and photonic components and systems. Its work is based on more than 40 years of experience in that field.

NEO performs irradiation tests based on international standards and advises companies regarding radiation qualification and hardening of components and systems. The knowledge obtained in years of radiation testing is also used for the development of new radiation sensor systems. These activities are performed either at irradiation facilities installed at INT or at partner institutions to which our scientists have regular access.

A multitude of modern equipment to measure electrical and optical parameters is available. Furthermore our institute runs a precision mechanical workshop and an electronic laboratory. This enables us to conduct most of the irradiation tests without help or equipment of the customer.

The activities within NEO are:

- Investigations of the effects in all kinds of radiation environments
- Performance, analysis, and evaluation of irradiation tests done at Fraunhofer INT and external facilities
- Ensuring the operability of components and systems in typical radiation environments, such as space, nuclear facilities, medicine, or accelerators
- Consulting users and manufacturers on the use of products in radiation environments by selecting, optimizing and hardening
- Measurement of the radiation effects on optical fibers and fiber Bragg gratings (FBG)
- Development of radiation sensors based on optical fibers, FBGs, oscillating crystals, UV-EPROMs, and SRAMs
- Participation in the development of international test procedures for IEC, IEEE, NATO, and IAEA
- Since 2013 all services of the business unit are certified according to ISO 9001

A.3. Irradiation facilities

Fraunhofer INT operates several irradiation facilities on site that are dedicated to perform irradiation tests. For that purpose the design and operation characteristics are highly optimised from many decades of experience and to comply with all relevant standards and test procedures.

Furthermore Fraunhofer INT accesses regularly external facilities, partly with dedicated irradiation spots for exclusive use to Fraunhofer INT.

These irradiation facilities are:

- Co-60 irradiation sources on site to simulate the effect of total dose
- Neutron generators on site to simulate the displacement damage of heavy particles
- 450 keV X-ray irradiation facility on site
- Laser induced single event test system on site
- Dedicated proton irradiation spot at the injector cyclotron of FZ Jülich to simulate the effects of solar and trapped protons
- External Co-60 irradiation sources for high dose and high dose rate irradiations

The facilities used in the context of this work will be described in detail in the following sections.

A.4. QM-Certificate



MANAGEMENT SYSTEM CERTIFICATE

Certificate No: 126306-2012-AQ-GER-DAKKS	Initial certification date: 13. February 2013	Valid: 29. March 2018 - 12. February 2019
---	--	--

This is to certify that the management system of



**Fraunhofer-Institut für
Naturwissenschaftlich-Technische
Trendanalysen INT**

Appelsgarten 2, 53879 Euskirchen, Germany

has been found to conform to the Quality Management System standard:

ISO 9001:2015

This certificate is valid for the following scope:

Scientific research on the effects of nuclear and electromagnetic radiation as well as application and development of methods for their characterization

Place and date:
Essen, 29. March 2018



For the issuing office:
DNV GL - Business Assurance
Schnieringshof 14, 45329 Essen, Germany



Thomas Beck
Technical Manager

Lack of fulfilment of conditions as set out in the Certification Agreement may render this Certificate invalid.
ACCREDITED UNIT: DNV GL Business Assurance Zertifizierung und Umweltgutachter GmbH, Schnieringshof 14, 45329 Essen, Germany.
TEL: +49 201 7296-222. www.dnvgl.de/assurance

B Irradiation details

B.1. Irradiation facility TK1000B

The TK1000B is a Co-60 gamma irradiator manufactured by Sauerwein Isotopentechnik, Germany. Inside the shielding container is a small radioactive pellet with a diameter of 7 mm and a length of 10.4 mm. The activity decreases with a physical half-life of 5.27 years. The current radioactive pellet was installed in the irradiator at 2012-01-25. The activity at that time was 16526 GBq.

In deactivated state the radioactive pellet is stored inside the shielding container allowing the operator to install the samples and conduct measurements without getting exposed to ionizing radiation.

On activation, the radioactive source is pushed into the source guiding tube in less than a second irradiating the surrounding volume.

The certificate of the radioactive source can be found in Appendix B.4.

Figure 12: TK1000B irradiation facility

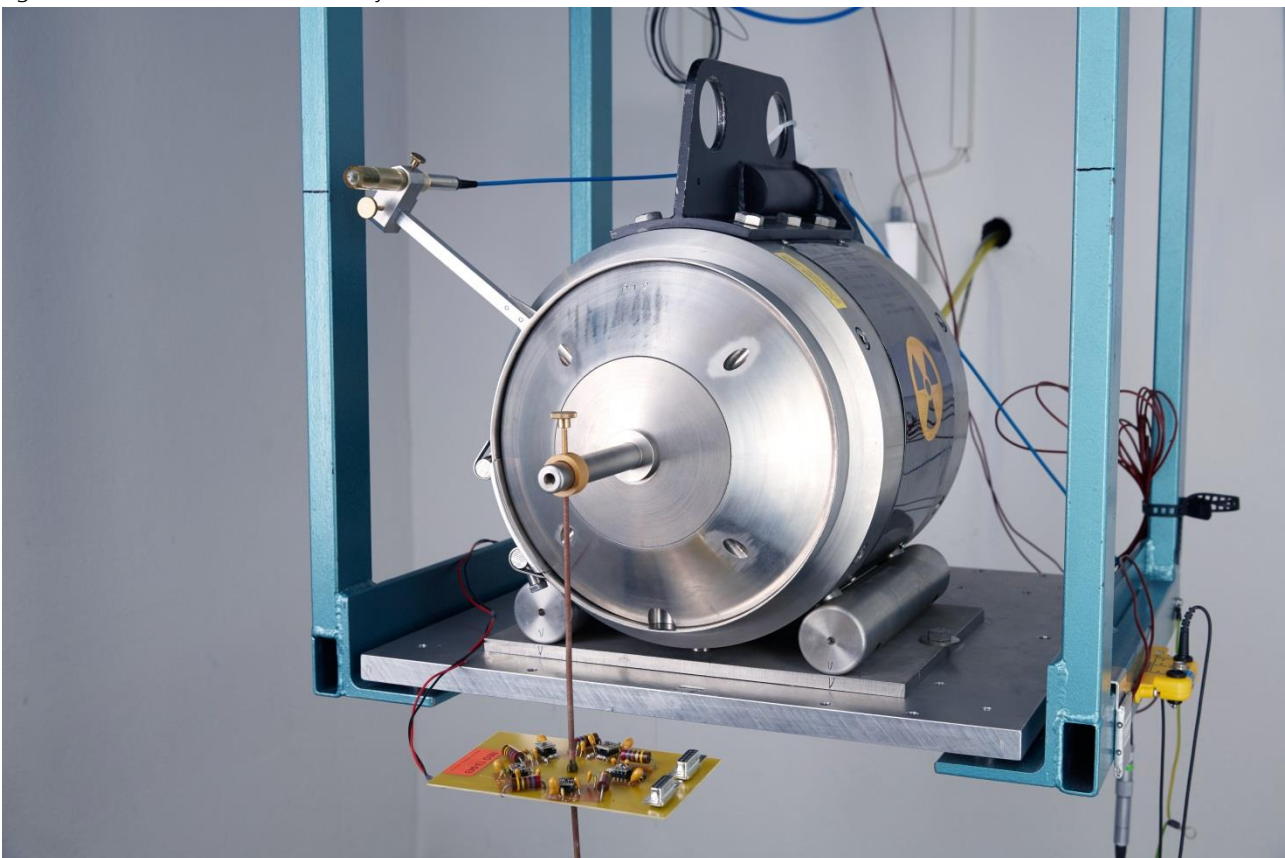

B.2. Radiation properties of TK1000B

The samples are irradiated with Co-60 gamma radiation. The radioactive Co 60 isotope decays by emitting beta radiation (i.e. electrons) into a highly excited Ni-60 isotope which emits two gamma photons to reach the stable ground state. The gamma radiation has two energy levels of 1.172 MeV and 1.332 MeV.

The gamma radiation of around 1 MeV is a penetrating radiation, so the samples are irradiated completely. The shielding of the sample holder and other surrounding material between the source and the sample is negligible.

The radiation is emitted from a point-like source. Thus the dose rate \dot{D} falls off with $1/r^2$ where r is the distance from the source.

$$\dot{D}(r) = \dot{D}_0 \cdot \frac{r_0^2}{r^2}$$

B.3. Dosimetry at TK1000B

The dosimetry is done regularly with calibrated ionisation chambers manufactured by IBA, Germany, and PTW Freiburg, Germany.

The dose rates obtained at varying distances between 2 cm and 50 cm and in different directions relative to the source are used to develop a model of the dose rate distribution around the source as a function of distance and direction. The dose rate of an individual measurement is scaled to a reference date taking the half-life of the radioactive isotope into account. This model is constantly checked and improved with each additional measurement of dose rates.

As a result a reliable description of the dose rates inside a specific volume arranged in a given geometry in the vicinity of the irradiation source is available.

The uncertainties of the reported dose rates are given by an uncertainty evaluation according to [2] and mainly result from the uncertainties of the dosimetry and positioning of the samples.

The uncertainty evaluation for this irradiation can be found in Appendix C.

B.4. Certificate of TK1000B irradiation source

IT-Service Leipzig		Ingenieur-Technischer Geräte- und Produktservice für Werkstoffprüfung und Medizintechnik
Qualitätszertifikat für umschlossene Strahlenquelle		TK 1000 B
Prüfungszeugnis - Nr.: Kunde:	12061 Fraunhofer Institut	
Strahler/HRQ Ident. Nr.: Kapsel Typ: ISO Code: AFNOR Code: Zertifikat Nr.:	001-2010(GK60R01) GK60R01 ISO/99/E 65546 NF/99/E 65546 RUS/5614/S-96 (Rev. 0)	
Radionuklid: Physikalische Form: Chemische Form:	Co-60 fest, umschlossen metallisch	
Brennfleck in mm x mm: Herstellungsaktivität: Herstellungsdatum:	7,0x10,4 mm 20102,1 GBq (543,3 Ci) 30.07.2010	
Dichtheitsbescheinigung		
Oberflächenkontaminationstest: Datum:	30.07.2010	ohne Beanstandung Ergebnis: < 185 Bq
Lecktest: Datum:	30.07.2010	ohne Beanstandung Ergebnis: dicht
Die Qualitätskontrolle wurde vom Hersteller in unserem Namen durchgeführt. Es wird bescheinigt, daß die umschlossene radioaktive Strahlenquelle den Anforderungen nach NF / ISO 9978 (1992), ISO 2919 (1999) und NF M61002 (1984) entspricht.		
Der oben genannte Strahler wurde in einem neuen bzw. entsprechend DIN 54115 Teil 6 überprüften und zugelassenen Strahlerhalter Nr.:		
eingebaut.		
Datum:	25.01.2012	Signum IT-Service:
		
<hr/> IT-Service Leipzig GmbH, BS Haan, Bergische Straße 16, 42781 Haan		
Tel.: 02129 / 377595		Fax: 02129 / 378794

C Irradiation documentation

Irradiation Test Documentation			
Irradiation Source	TK1000B (2012)	Date	01.03.2017
Responsible Employee	MS		
Project Description	NEO-14-086 TOPSIDE SiC Run #3		
Reference Data for Dose Rate Calculation			
Reference Activity	8.45 TBq ± 10.0%	Standard uncertainty ¹⁾	
Reference Dose Rate	2.35 Gy/s ± 2.5%	Standard uncertainty ¹⁾	
Reference Distance	10 cm ± 0.5%	Standard uncertainty ¹⁾	
Reference Date	01.01.1990		
Geometry of Irradiated Object (As defined or measured):			
Inner Diameter	8.70 cm ± 0.05 cm	Standard uncertainty ¹⁾	
Outer Diameter	11.40 cm ± 0.05 cm	Standard uncertainty ¹⁾	
Height	0.50 cm ± 0.05 cm	Standard uncertainty ¹⁾	
Distances of Point Source:			
Surface of Object	15.50 cm ± 0.05 cm	Standard uncertainty ¹⁾	
Object Minimum	16.09 cm ± 0.05 cm	Standard uncertainty ²⁾	
Object Maximum	17.00 cm ± 0.07 cm	Standard uncertainty ²⁾	
Mean Distance	16.54 cm ± 0.11 cm	<i>Expanded uncertainty³⁾</i>	
Dose Rates in Object			
Minimum	0.0230 Gy/s ± 2.8%	Standard uncertainty ²⁾	
Mean	0.0243 Gy/s ± 2.8%	Standard uncertainty ²⁾	
Maximum	0.0257 Gy/s ± 2.8%	Standard uncertainty ²⁾	
Irradiation Time	4107516 s ± 1 s	Standard uncertainty ¹⁾	
in DD HH:MM:SS	16 12:58:36 ± 1 s	Standard uncertainty ¹⁾	
Dose in Object			
Minimum	94591 Gy ± 2.8%	Standard uncertainty ²⁾	
Maximum	105723 Gy ± 2.8%	Standard uncertainty ²⁾	
Mean	100000 Gy ± 5.5%	<i>Expanded uncertainty³⁾</i>	
Homogeneity	11.1%		
¹⁾ Experience or statistics based estimation of standard uncertainty with a coverage factor k=1 ²⁾ Combined standard uncertainty with a coverage factor k=1 ³⁾ Determined from a combined standard uncertainty (i.e., estimated standard deviations of values above) and a coverage factor k = 2. Since it can be assumed that the possible estimated values of the dose are approximately normally distributed with approximate standard deviation, the unknown n value of the dose is believed to lie in the interval given with a level of confidence of approximately 95 %.			
<small>Standard Irradiation Test Documentation Sheet, 2015-12-18</small>			